

Aspens Springs

Roberts Creek Road
Porepunkah, 3740
Victoria

Aspens Springs provides farm stay accommodation. An array of farm activities is offered, including feeding of farm animals, pony rides, and fishing. There are also facilities for special interest groups such as artists, photographers, gardeners, paragliders, horse riders, bushwalkers and birdwatchers. The owners are very willing to help anyone with access needs. There are 3 cottages in total, with one being set up with adequate accessibility - Peacock Barn. Peacock Barn can sleep up to ten people. Another cottage has an accessible bathroom, which can be accessed through a carport. All cottages are fully self-contained.



Picture 1. Entry

Reservations:

Phone: 03 5756 2400
Fax: 03 5756 2190
TTY: Nil
Web: <http://www.aspensfarmpark.com.au>
Email: aspens@aspensfarmpark.com.au

Transport:

Aspens Springs is located 4km from Bright on Roberts Creek Road, off the Back Porepunkah Road. There is no public transport, so is best reached by private car or coach.

Parking:

There are no designated accessible parking bays, however there is plenty of space to park. Parking is over loose gravel, with a firm base underneath.

Reception Entry and Foyer:

Reception can be found up the hill at the owner's home. It is best reached by car/coach, and is clearly signed. At the house there is no designated accessible parking bays, however there is plenty of spaces to park. Parking is over loose gravel on a firm base and there is a clear path of travel to the reception. Distance to reception is approximately 10m and includes a ramp with a 12% gradient. The ramp is made of timber slats. It is 2050mm wide and approximately 6m long. A 20mm step needs to be negotiated to get onto the ramp. The door into reception is light, inward opening, and is 760mm wide. The handle is a knob, 900mm high. There is plenty of circulation space once in the reception area, over floorboards. Lighting is good and a doormat is the only potential hazard. There is no counter to negotiate.



Picture 2. Reception entry

Once you have received your keys it is then a short drive back down the hill to the cottages where parking can be found immediately outside each building. Once again the surface is loose gravel over a firm surface. It is generally flat (maximum gradient 7.6%) with plenty of space to unload luggage.

The owners are very happy to help with the handling of luggage.

Accommodation entry:

All buildings are have clear location signs. The main entry into Peacock Barn is via a ramp, gradient 8.6%, length 1150mm. There are double sliding doors (2x800mm wide, medium weight), with screen doors in front. Handle height for the screen doors is 1120mm, for glass doors 1050mm (D handle). There is a threshold height of 40mm. Concrete is found on either side of the entry.

There is a second entry to the right of the sliding doors, which has a ramp and railings. The concrete ramp has a gradient of 12% and is 2700mm long, 1300mm wide. There is a small lip of 50mm to negotiate at the beginning of the ramp. There is then a flat circulation space at the top of the ramp (1300mmx1300mm) for an outward opening door, 830mm wide.

Handle height is 900mm. This entry takes you to the corridor of which the bathrooms come off. There are no emergency exit signs. Audible fire alarms are installed.



Pictures 3 & 4. Main entry and second entry

Living Area:

The kitchen, dining and lounge rooms are all separate. The main entrance takes you into the dining room, which has a large circulation space. There are two trestle style dining tables, 770mm high, and knee clearance of 730mm. Both sit up to six people.

There is a 80mm step into the kitchen from the dining area. The door is an internal cavity slide, and is 750mm wide. In the kitchen the bench is 900mm high, with no knee space. Microwave height is 950mm, and the dishwasher and stove are accessible. There is a reach of 450mm for the tea and coffee facilities. There is generally good circulation space for side on access.



The door from the dining room into the lounge room is concertina style and has a clearance of 2080mm. There is a step of 120mm, and a portable ramp 1200mm long, with a gradient of 10%. The lounge area has a very large circulation space and can easily be altered to suit by moving furniture. Floor surface is low pile carpet. There are four two seater couches and one single seater. There is a remote control for the television.

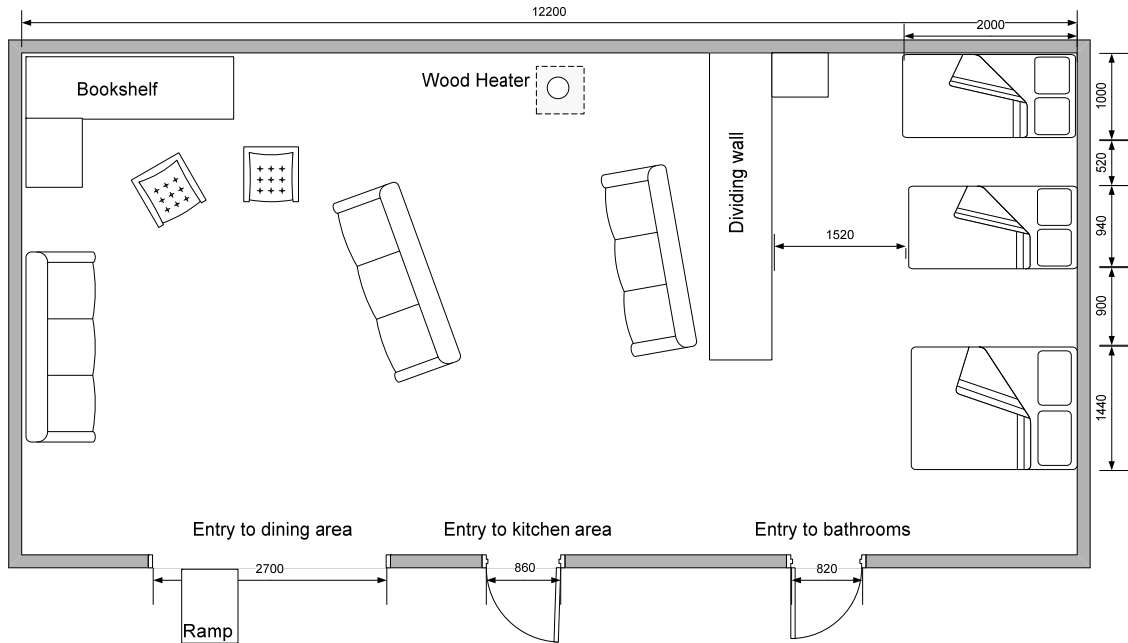

Figure 1. Living and open plan bedroom floor plan

Bedrooms:

There are two open plan bedroom areas. The one with the best circulation space comes off the lounge area. There are 3 beds in this area, one double and two single. Next to the double bed is adequate space for a transfer. The height of this bed is 520mm, and the bed can be raised with blocks if available. The current clearance is 130mm. NB neither single bed has under clearance. It is possible to move furniture to enable hoist transfers. There is a freestanding wardrobe with a hanging height of 1500mm. There is no mirror. Floor surface is low pile carpet.



Picture 7. Open plan bedroom

Bathrooms:

There is a purpose built accessible bathroom in Peacock Barn. It is located next to the above mentioned bedroom, via a 1390mm wide corridor. Entry into this corridor is via a 820mm wide doorway with a permanent threshold ramp 50mm high. The door into the bathroom is 780mm wide. It is inward opening, light, and does not self-close. The handle is a knob and is 940mm high. Once in the bathroom there is adequate circulation space, and floor is tiled. There are two mirrors. One full length, 660mm-1620mm high, the other above the sink, 1230mm-1980mm high. The washbasin is accessible at 760mm high and 360mm deep. It has a knee depth clearance of 180mm and knee height clearance of 620mm. Taps are lever style and are 830mm high.

The shower has good circulation space and has a curtain on one side. Access to the shower is flat. There is a horizontal grab rail. It starts at 800mm high for 850mm in length, and then drops to an oblique section 500mm in length. There is a hand held shower nozzle. The taps are 2 x single lever capstan, and are 960mm high. There is a shower chair available with adjustable legs. The height range of which is 400mm-600mm.



Pictures 8 & 9. Shower and toilet

The toilet is a right hand transfer and is 400mm high. Centerline of the toilet to the nearest object is 450mm, and front of seat to rear is 840mm. There is a continuous L shaped side and rear grab rail which comes out 280mm for the wall across the back of the toilet. It is 780mm high.

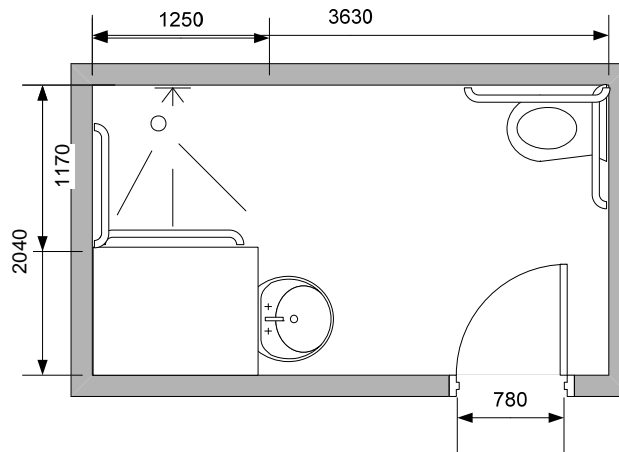

Figure 2. Floor plan of main bathroom

There is also a bathroom at one of the other cottages, which has reasonably good accessibility. It can be entered into via a concrete carport, which has a gradient of 10.9% and decreases to 4.2% at the bathroom doorway. The door is light, inward opening, with a knob handle 1200mm high. It is 700mm wide. The flooring in the bathroom is slate tiles. There is a flat entry into the shower, which has a hand held shower nozzle, and lever Capstan taps (1190mm high). The toilet is 400mm high, however there is no space for a side transfer. There are no rails in the toilet or shower areas. The sink is 820mm high and 450mm deep. There is no knee clearance. Tap height is 860mm, and the mirror above the sink is 1200mm-1770mm.